

BILL OF MATERIAL

MARK	QTY	DESCRIPTION	LENGTH	WEIGHT	REMARKS
165ST1	1	STRINGER			
165ST1	1	C12X20.7	12'-6 1/4"	259	A36
a40	3	L3X3X5/16	0'-6"	9	A36
a128	1	L4X4X3/8	0'-11 3/4"	10	A36
a144	1	L3X3X1/4	1'-1 1/2"	6	A36
a171	1	L6X3-1/2X3/8	0'-5"	5	A36
m221	1	C12X20.7	2'-5 9/16"	51	A36
m223	1	C12X20.7	4'-5 7/16"	92	A36
m229	1	C12X20.7	11'-7 13/16"	241	A36
p168	1	FL3/8"x6"	0'-8"	5	A36
p182	1	FL1/4"x3"	0'-8 1/8"	2	A36
TOTAL WEIGHT THIS DRAWING				679	

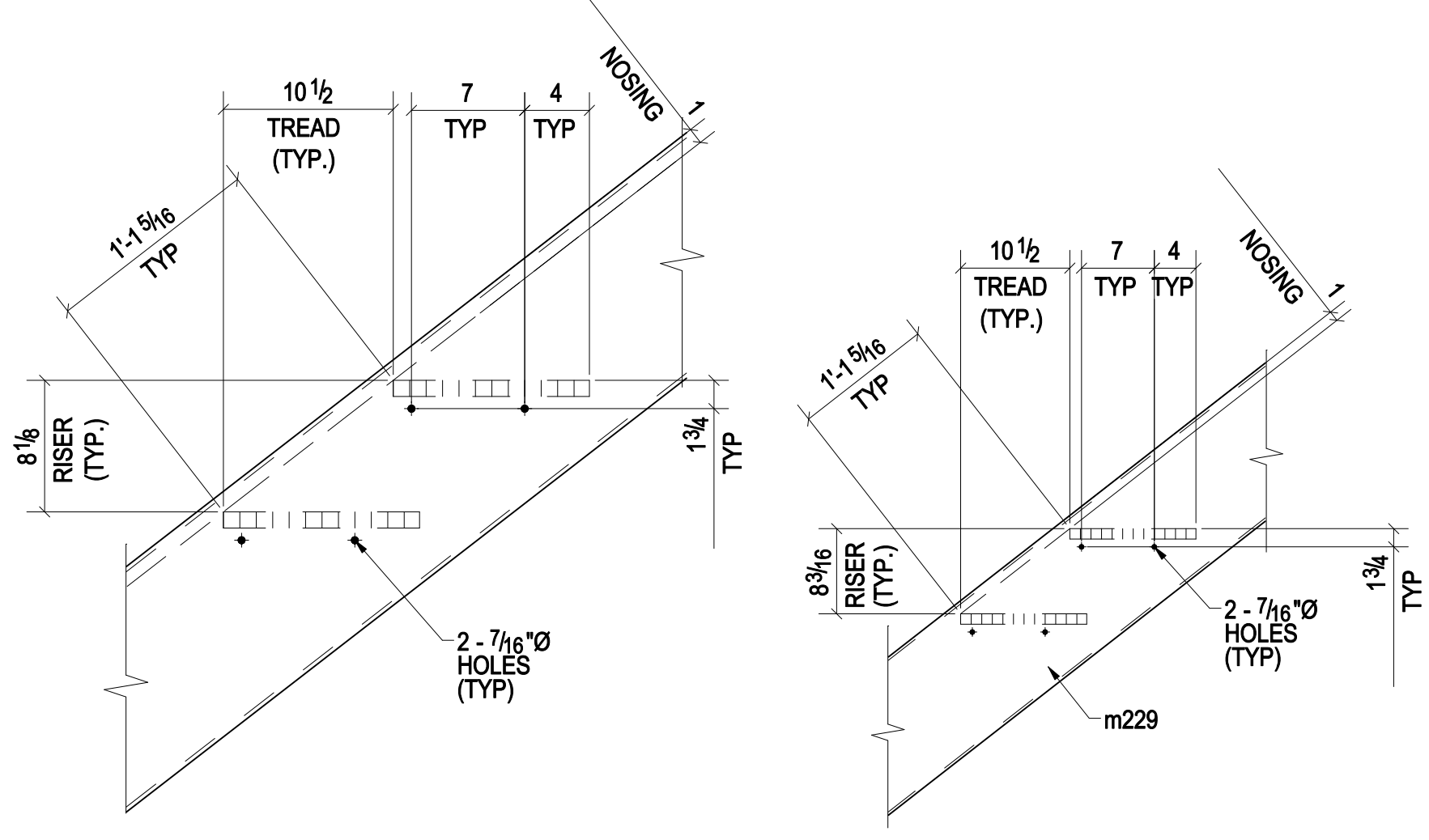
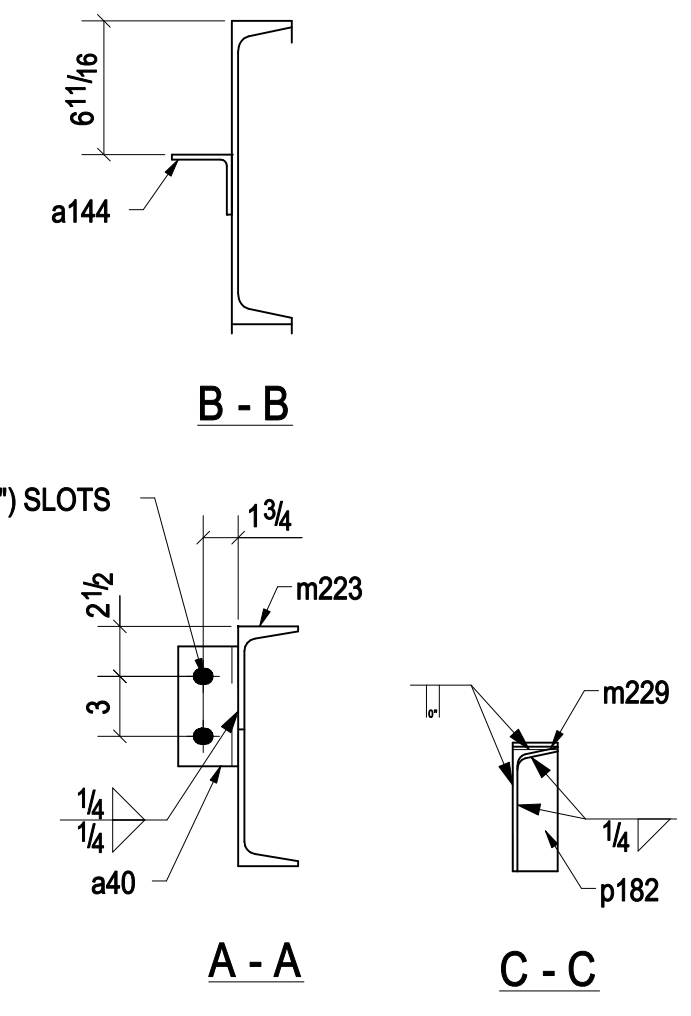
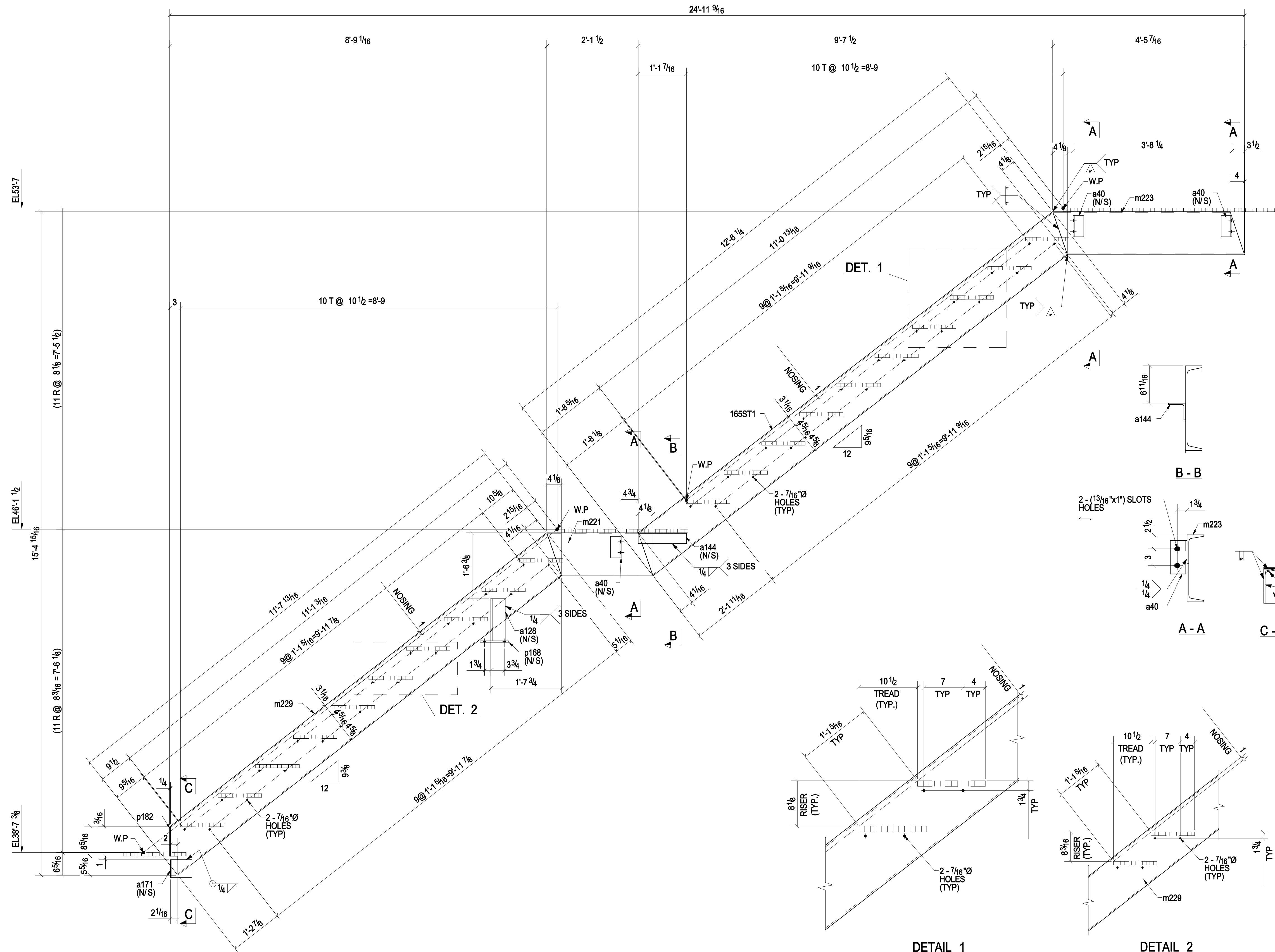

ONE - STRINGER - 165ST1

GALV.
1

Total Qty.	Unit Qty.	Bolt Size & Length
40	40	BOLT 3/8" Ø A307 0'-1 1/2"
2	2	BOLT 3/4" Ø A325N 0'-2 1/4"

REVISIONS 1 REVISED AS MARKED FOR FABRICATION		
NO.	REVISION	DATE
PROJECT NAME:		
LOCATION:		
CONTR: ---		
DRAWN BY: ---		
DATE: ---		
CHECKED BY: ---		
JOB NO. ---	STRINGER	SHEET NO. 165