

BILL OF MATERIAL

MARK	QTY	DESCRIPTION	LENGTH	WEIGHT	REMARKS
172VB1	1	V_BRACE			
172VB1	1	HSS6X6X1/2	9'-8 1/4"	321	A500-GR.B
p21	4	PL1/4"X2 11/16"	0'-0"	5	A36
TOTAL WEIGHT THIS DRAWING					629

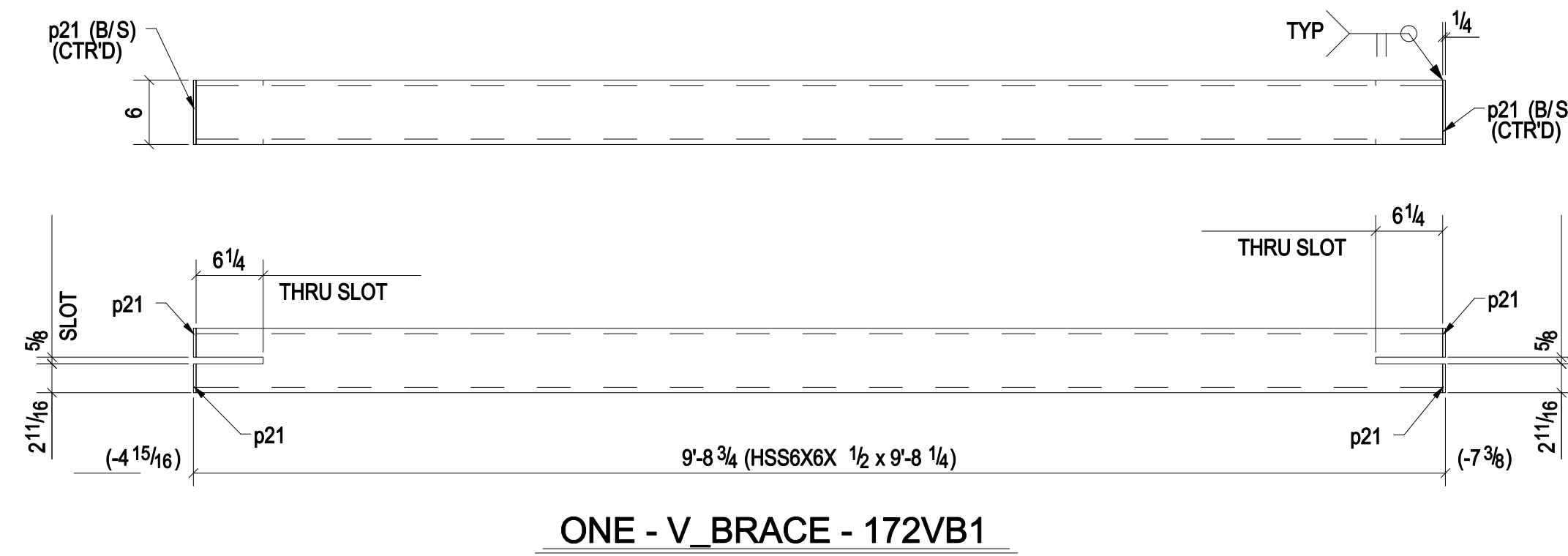

PROJECT PHASING		
MARK	QTY	PHASE
172VB1	1	Phase 1
172VB2	1	Phase 1

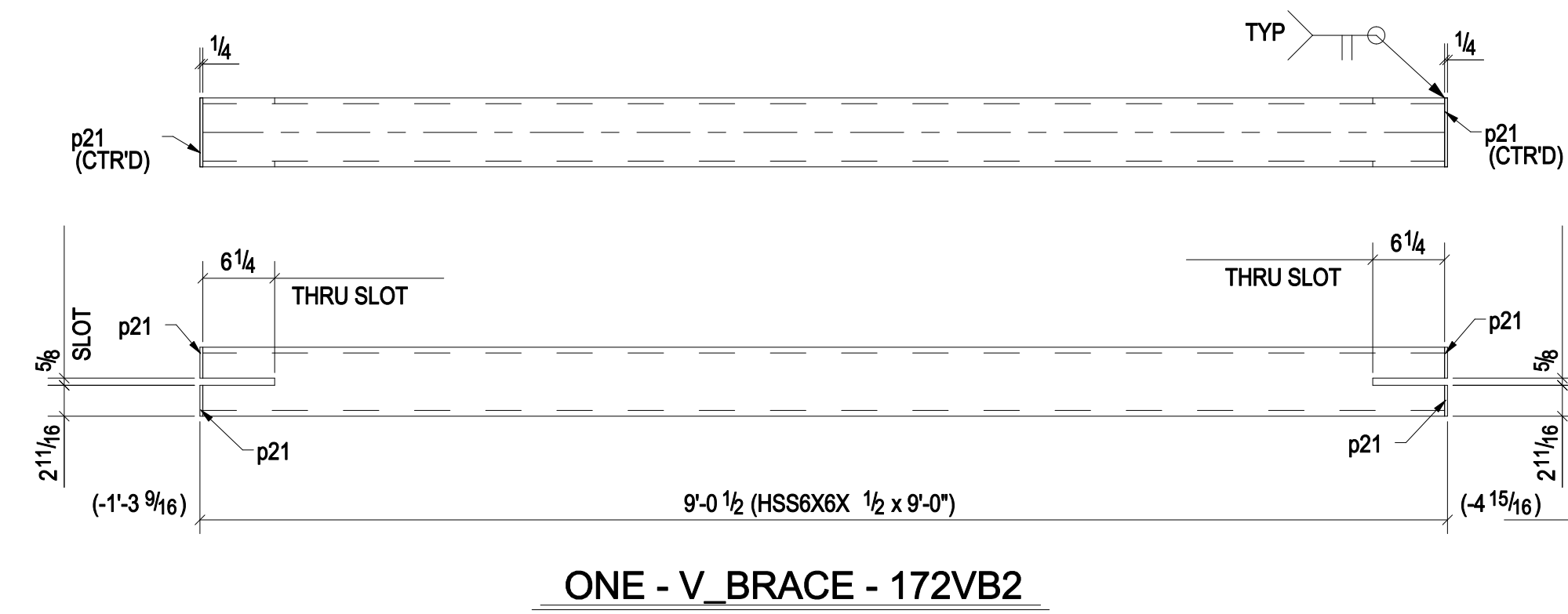

05/26/14		FOR APPROVAL					
PRINT RECORD							
DATE	APP.	SHOP	FIELD	DIST.	COORD.	F.C.	OFFICE
MATERIAL:				SHOP DRAWING DISCLAIMER			
A36 UNO				ALL INFORMATION PROVIDED ON THESE DRAWINGS ARE PREPARED IN ACCORDANCE TO THE CONTRACT DOCUMENTS AND THE SPECIFICATIONS. ALL CLOTTED AREAS SHOW WE DUE TO LACK OF INFORMATION PROVIDED BY THE CONTRACT DOCUMENTS OR SPECIFICATIONS, BUT PREPARED WITH ALL THE INFORMATION AVAILABLE TO US. WE MUST HAVE THESE AREAS ANSWERED BY THE GENERAL CONTRACTOR, ARCHITECT, ENGINEER, BEFORE WE CAN START FABRICATING ANY MATERIAL. PLEASE RESPOND WITH THIS INFORMATION BY MARKING UP OUR SHOP DRAWINGS.			
HOLE SIZE:		BOLT GRADE:		MINIMUM WELD:		ELECTRODE:	
13/16" Ø UNO		A325-N UNO		3/16"		E-70XX	
ARCH:				JOB NAME & LOCATION:			
ENGR.							
CONTR.				JOB: 14-111			
DRAWN BY: DMT 05/26/14				CHECKED BY: SK 05/26/14			
SHEET TITLE: V_BRACE				SHEET: 172			
MODIFIED DATE: 05/26/14		LAST PLOT DATE: 05/26/14		CAD FILENAME: 172			