

DETAIL-A
(19 LOCATIONS)

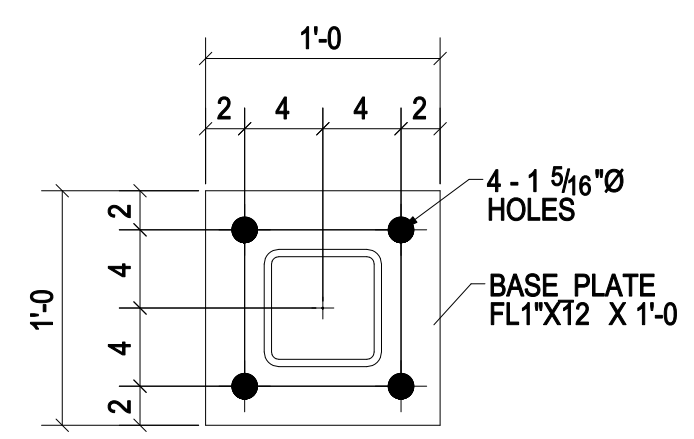

DETAIL-B
(06 LOCATIONS)

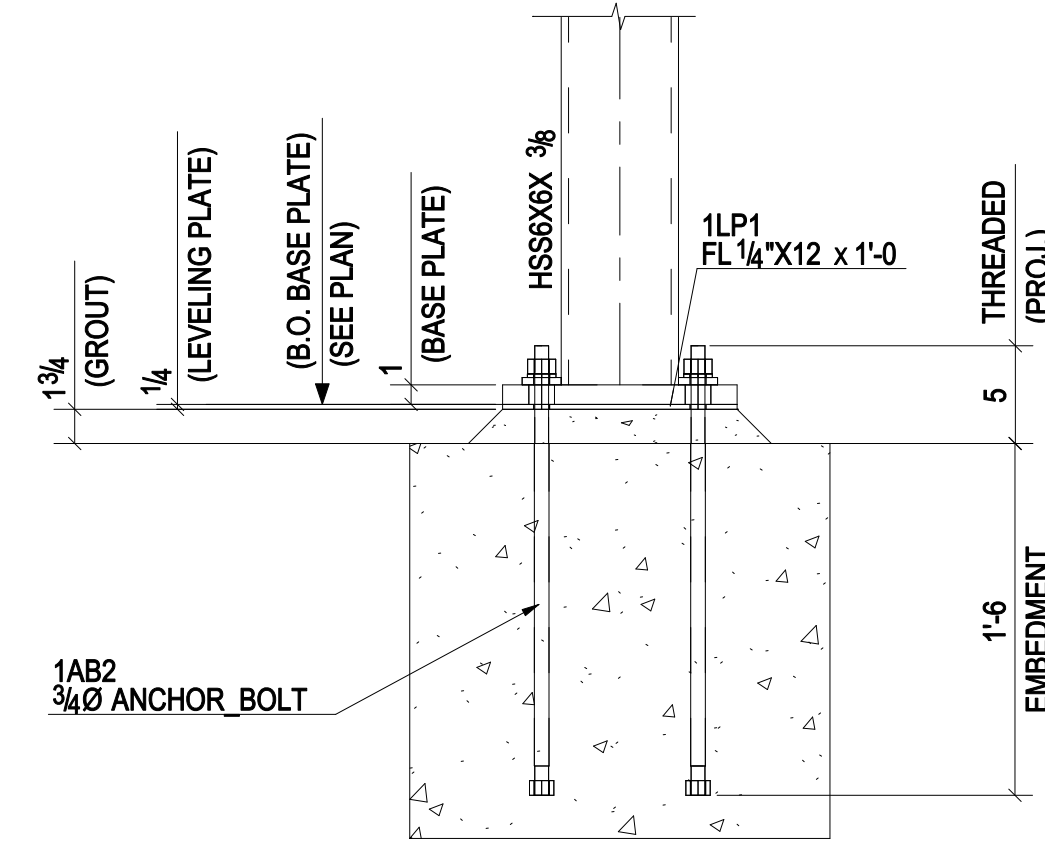
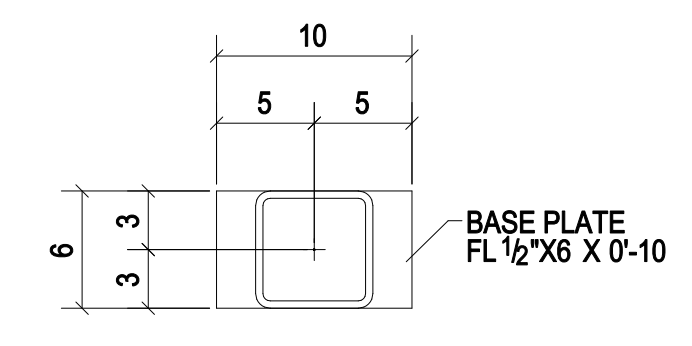
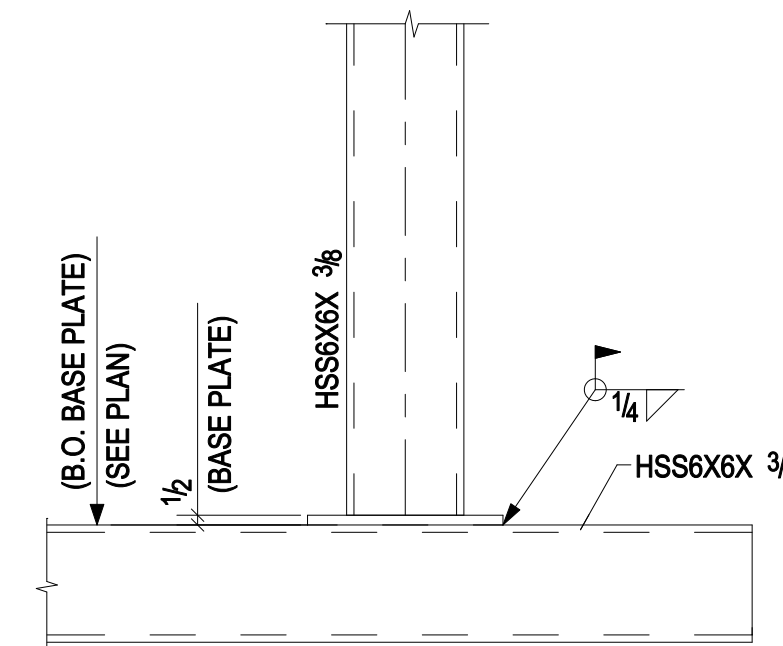

DETAIL-C
(02 LOCATIONS)

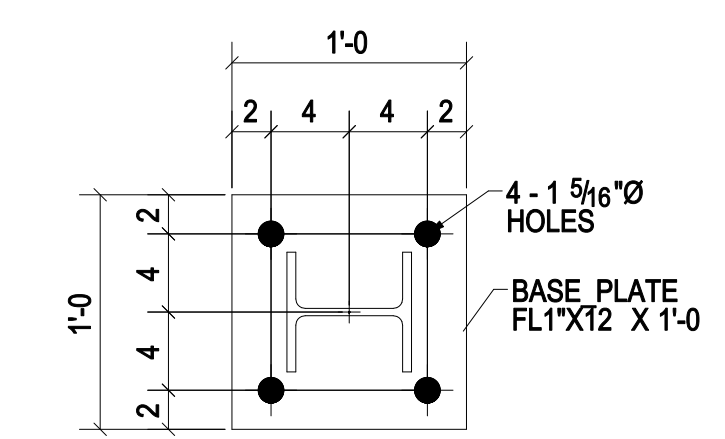
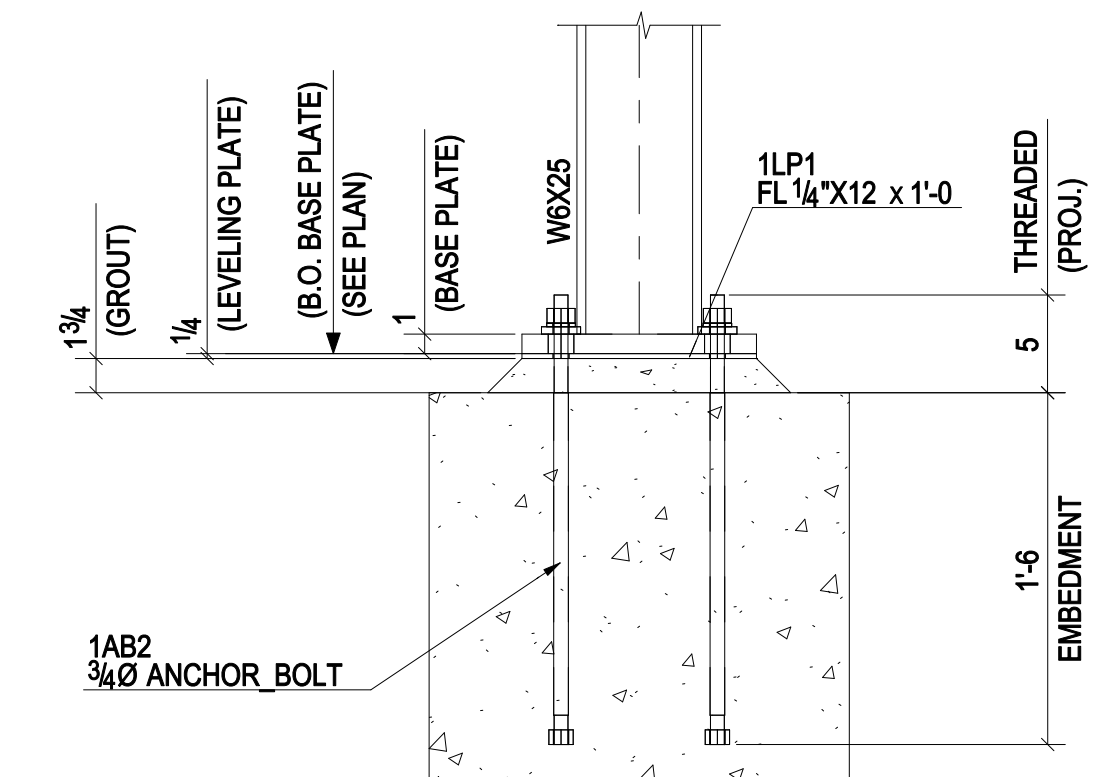

DETAIL-D
(04 LOCATIONS)

NOTES:-
1. APPROVER PLEASE VERIFY/ PROVIDE ALL CLOUDED PORTIONS.

<p>05/26/14 FOR APPROVAL</p>							<p>PRINT RECORD</p>		<p>SHOP DRAWING DISCLAIMER</p> <p>ALL INFORMATION PROVIDED ON THESE DRAWINGS ARE PREPARED IN ACCORDANCE TO THE CONTRACT DOCUMENTS AND THE SPECIFICATIONS. ALL CLOUDED AREAS SHOWN ARE DUE TO LACK OF INFORMATION PROVIDED BY THE CONTRACT DOCUMENTS OR SPECIFICATIONS, BUT PREPARED WITH ALL THE INFORMATION AVAILABLE TO US. WE MUST HAVE THESE AREAS ANSWERED BY THE GENERAL CONTRACTOR, ARCHITECT, ENGINEER, BEFORE WE CAN START FABRICATING ANY MATERIAL. PLEASE RESPOND WITH THIS INFORMATION BY MARKING UP OUR SHOP DRAWINGS.</p>		
DATE	APP.	SHOP	FIELD	DIST.	COORD.	F.C.	OFFICE				
MATERIAL:		HOLE SIZE:		BOLT GRADE:		MINIMUM WELD:		ELECTRODE:			
A36 UNO		13/16" Ø UNO		A325-N UNO		3/16"		E-70XX			
<p>ARCH:</p> <p>ENGR:</p> <p>CONTR.</p>							<p>JOB NAME & LOCATION:</p>				
<p>DRAWN BY: PC 05/26/14</p> <p>CHECKED BY: SK 05/26/14</p>							<p>JOB: 14-111</p> <p>SHEET: AB2</p>				
<p>SECTION & DETAILS (SECTOR A)</p>							<p>MODIFIED DATE: 05/28/14 LAST PLOT DATE: 05/28/14 CAD FILENAME: AB2</p>				